

The effect of disturbance factor on the stability of tunnels (Case study: Tunnel No.2 of Kurdistan)

MohammadrezaRajabi Khamseh¹, Vahid Hosseinitoudeshki^{2*}

(1- Department of Civil Engineering, Urmia Branch, Islamic Azad University, Urmia, Iran)

(2- Department of Civil Engineering, Qazvin Branch, Islamic Azad University, Qazvin, Iran)

*Corresponding Author E-mail: toudeshki@gmail.com

ABSTRACT : Disturbance factor (D) is related to excavation method and cause damage and stress relief in the rock masses. The convergence and plastic zone around tunnels depends on the disturbance factor of rocks. This study has been in the tunnel No.2 of Kurdistan in NW of Iran which is composed of shale rocks. In tunnel modeling, different disturbance factors (0 to 1) are analyzed using phase2 software and the amount of displacement and extent of plastic zone in around the tunnels is determined. The obtained results show that by increasing of disturbance factor, the displacement and plastic zone around the tunnel has increased and the most increase has occurred in disturbance factors 0.8 to 1. Therefore, for excavation of this tunnel, the blasting method should not be used and instead of it, the mechanical methods must be used.

Keywords: Disturbance factor (D), Displacement, Plastic zone

I. INTRODUCTION

Disturbance factor (D) which introduced by [1] is related to excavation method and caused damage and stress relief in the rock masses. This factor may also be considered in the estimate of rock mass modulus from intact rock modulus. Excavation by Tunnel Boring Machine or hand excavation in poor quality rock masses results in minimal disturbance to the rock mass surrounding a tunnel. Very poor quality blasting in hard rocks results in much disturbance in surrounding a tunnel [1]. The selection of the disturbance factor (D) is a technical support question that arises frequently in relation to the use of the Hoek-Brown failure criterion. The most important point in relation to the estimation of the disturbance factor (D) is that this factor should not be applied to the entire rock mass surrounding the excavation. The disturbance factor (D) should only be applied to the actual zone of damaged rock [2].

The study area is located in Sanandaj - Sirjan structural zone [3] which has been affected regional convergence in the NE-SW direction. In the regional tectonic, Sanandaj - Sirjan zone is located in the Turkish-Iranian plateau [4]. It extends from eastern Anatolia to eastern Iran, and typically has elevations of 1.5–2 km. The tunnel No.2 of Kurdistan will be excavated in shale rocks in this area.

II. MATERIAL CHARACTERISTICS OF SHALE ROCKS

The physical and mechanical characteristics of the shale rocks were determined on obtained samples of boreholes and field tests on outcrops. The specific gravity of these rocks varies from 2.63 to 2.67 and the average value is 2.65.

The values of minimum and maximum UCS varies from 18 to 22 MPa respectively, and the average value is 20 MPa. The low values of the UCS are mainly due to weak nature of these rocks. Therefore, according to ISRM [5], the shale rocks proved to be weak rocks. In addition, based on [6], using the UCS, very low strength was suggested for these rocks. The Poisson's ratio is 0.3, cohesion is 0.384 MPa and friction angle is 32.98°. The average value for the rock material constant m_i was determined using Hoek and Brown failure criterion [7]. The value of m_i for these rocks was obtained equal to 6.

III. CLASSIFICATION OF THE ROCK MASSES

The RMR and Q ratings have been determined using field data and the mechanical properties of intact rock samples. The Rock Mass Rating (RMR) System [8], classifies rock masses using the following parameters: uniaxial compressive strength (UCS), Rock Quality Designation (RQD), spacing of fractures, condition of fractures, groundwater conditions, and orientation of fractures. The average RMR rating for the rock masses assessed to be 46. This rating classifies the shale rocks as fair rock masses.

The Q rock mass classification system is also known as the NGI (Norwegian Geotechnical Institute) have been developed by Barton et al. [9]. It is defined in terms of RQD, the function of joint sets (J_n), discontinuity roughness (J_r), joint alteration (J_a), water pressure (J_w) and stress reduction factor (SRF). The

average Q value for the rock masses is equal to 2.145. According to the Q classification system, the shale rocks can be considered as poor rock masses.

IV. MECHANICAL PROPERTIES OF THE ROCK MASSES

The rock mass properties such as the rock mass strength (σ_{cm}), the rock mass deformation modulus (E_m) and the rock mass constants (m_b , s and a) were calculated by the Rock-Lab program defined by Hoek et al. [1]. This program has been developed to provide a convenient means of solving and plotting the equations presented by Hoek et al. [1].

In Rock-Lab program, both the rock mass strength and deformation modulus were calculated using equations of Hoek et al. [1] and the rock mass constants were estimated using equations of Geological Strength Index (GSI) [1] together with the value of the shale material constant. Mean RMR values have been used to estimate the GSI index for these rocks that exhibiting strain-softening behaviour.

Finally, the shear strength parameters of the rock mass (C and ϕ) for the rock masses were obtained using the relationship between the Hoek–Brown and Mohr–Coulomb criteria [10] and are presented in Fig.1.

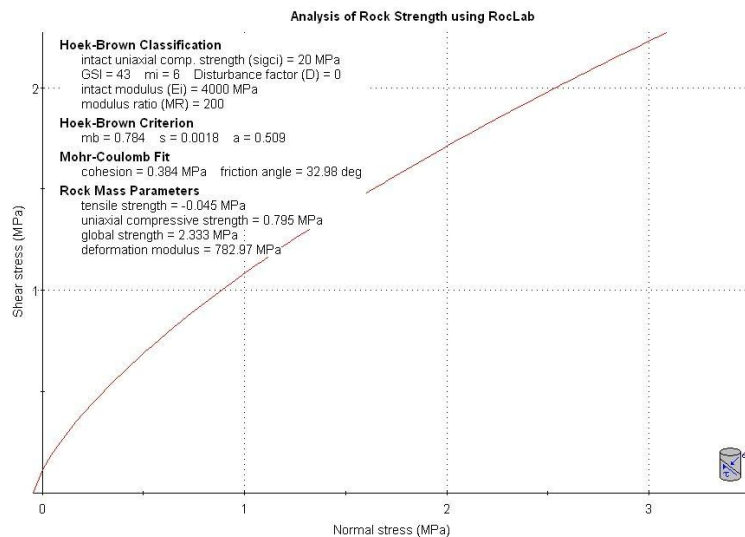

Fig.1. Rock mass parameters for zero disturbance factors

V. MATERIAL AND METHODS

The numerical method using the computational code (phase2) has been applied in analyzing the tunnel. Phase2 is a two dimensional program which planned based on infinite elasto-plastic elements that used for calculation the stresses and displacements around the underground excavations. In this paper, the tunnel is simulated in shale rocks and with disturbance factor 0 to 1. Numerical analysis was based on two dimensional analyzing and plane strain.

VI. THE TUNNEL MODELING

For modeling of the tunnel in shale rock masses a finite element model for horseshoe tunnel with span of 12.5 meters are used. The external boundary of models is located in distance 5 times of tunnel diameter and graded meshes with 6 nodes are used in finite element meshing (Fig. 2).

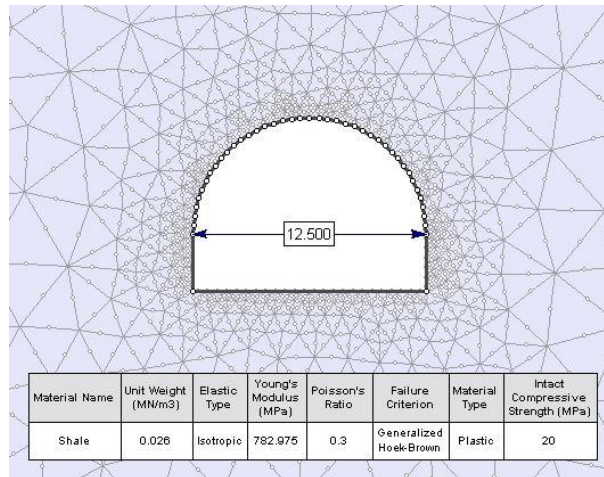

Fig. 2. The modeling of tunnel with span of 12.5 m

Numerical analysis of the tunnel No.2 of Kurdistan includes analysis the amount of convergence and plastic zone around of tunnel in different disturbance factors.

VII. CONVERGENCE AROUND THE TUNNEL

In order to surveying the convergence around the tunnel No.2 of Kurdistan, the amount of displacement in the roof of tunnel for different disturbance factors is determined (for example in Fig. 3) and is represented in diagram of Fig. 4.

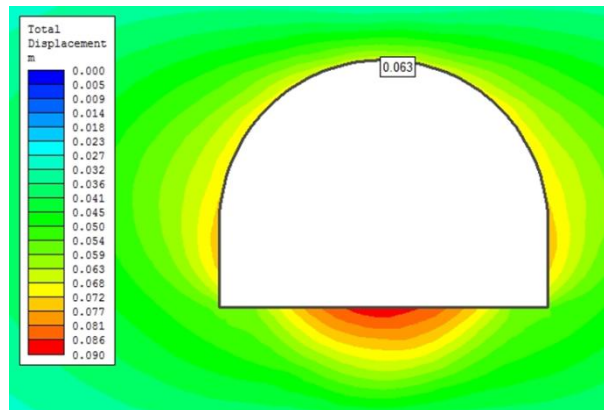

Fig. 3. The amount of displacement in the roof of tunnel for zero disturbance factors

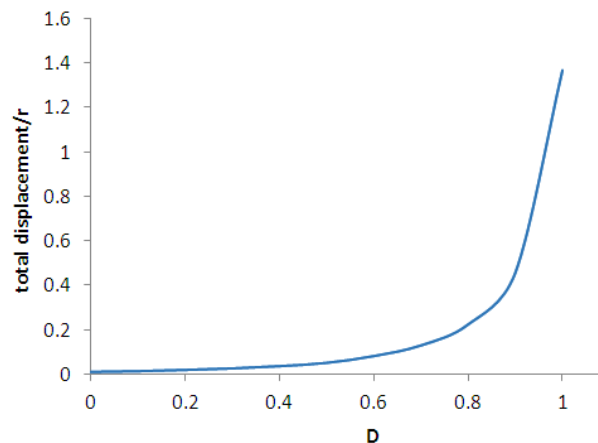

Fig. 4. The ratio of displacement to tunnel radius for different disturbance factors

Diagram in Fig.4 shows that by increasing disturbance factor, the ratio of displacement in the roof of tunnel increases and the most increase is in disturbance factors of 0.8 to 1. Since these disturbance factors is related to very poor quality blasting method, therefore for excavation of the tunnel No.2 of Kurdistan,the blasting method should not be used.

VIII. PLASTIC ZONE AROUND THE TUNNEL

To evaluate the plastic zone around the tunnel No.2 of Kurdistan, the radius of plastic zone in the roof of tunnel for different disturbance factors is determined (for example in Fig. 5) and is represented in diagram of Fig. 6.

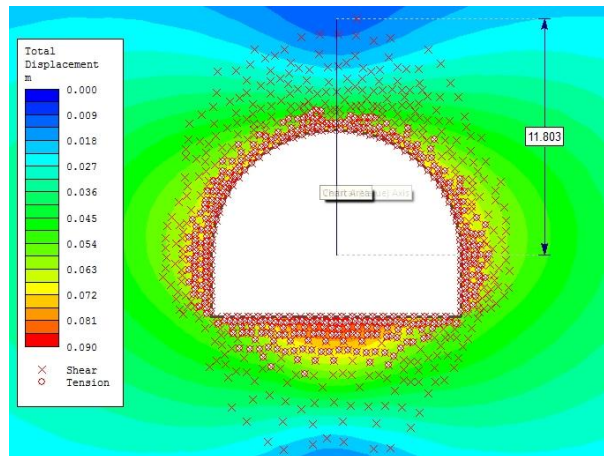

Fig. 5. The radius of plastic zone in the roof of tunnel for zero disturbance factors

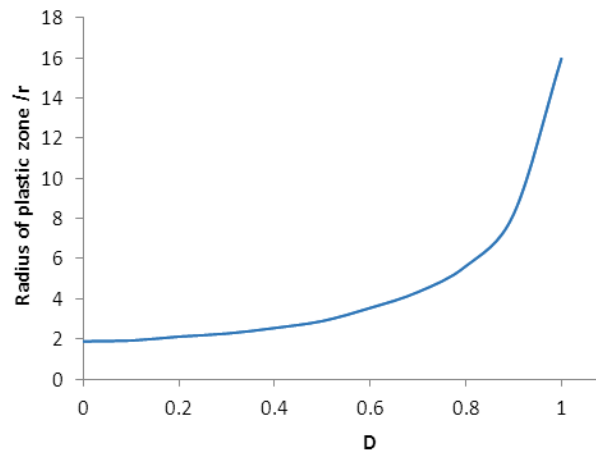

Fig. 6. The ratio of the radius of plastic zone to tunnel radius for different disturbance factors

Diagram in Fig. 6 shows that by increasing disturbance factor, the ratio of the radius of plastic zone in the roof of tunnel increases and the most increase is in disturbance factors of 0.8 to 1. It also implies that for excavation of the tunnel No.2 of Kurdistan, the blasting method should not be used and instead of it, the mechanical methods must be used.

IX. CONCLUSIONS

In this study that with purpose of investigating the effect of disturbance factor on the stability of the tunnel No.2 of Kurdistanis accomplished the following results have been obtained:

- By increasing the disturbance factor, the displacement and plastic zone around the tunnel is increased.
- The most of increase of displacement and plastic zone is occurred in disturbance factors of 0.8 to 1.
- The obtained results imply that for excavation of the tunnel No.2 of Kurdistan, the blasting method should not be used.

REFERENCES

- [1] E.Hoek, C.T.Carranza-Torres and B.Corkum, Hoek-Brown failure criterion-2002 edition. In: Proceedings of the fifth North American rock mechanics symposium, Toronto, Canada, 1,2002, 267-273
- [2] E.Hoek, Blast damage factor D, Technical note for Roc news. February, 2,2012
- [3] A. Aghanabati, Geology of Iran. Geological Survey of Iran,2004,619 pp
- [4] M.B.Allen, J.A.Jackson and R.Walker, Late Cenozoic reorganization of the Arabia-Eurasia collision and the comparison of short-term and long-term deformation rates. Tectonics, v. 23, art. no. TC2008, doi: 10.1029/2003 TC001530,2004
- [5] International Soil and Rock Mechanics ISRM, In: Brown ET (Ed.), Rock Characterization, Testing and Monitoring, ISRM Suggested Methods. Pergamon Press, Oxford, 1981,p 211
- [6] D.U.Deere and R.P.Miller, Engineering classification and index properties of intact rock. Tech. Rept. No. AFWL-TR-65-116, Air Force Weapons Lab., Kirtland Air Force Base, New Mexico, 1966,308 pp
- [7] E.Hoek and T.Brown, The Hoek-Brown failure criteria—a 1988 update, In: Proc. 15th Canadian Rock Mech. Symp, 1988,31-38
- [8] Z.T.Bieniawski, Engineering Rock Mass Classification. Wiley, New York.1989,251pp
- [9] N.R.Barton, R.Lien and J.Lunde, Engineering classification of rock masses for the design of tunnel support. Rock Mech, 4,1974, 189-239
- [10] E.Hoek and T.Brown, Practical estimates of rock mass strength. Int. J. Rock Mech. Min. Sci, 34 (8), 1997, 1165-1186